

Palletiser

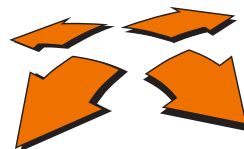

A **GALDI** COMPANY

ARTEMA PACK
packaging & automation



FULL AUTOMATION

From pallet loading to wrapping, the palletising station can be fully automated.

OPTIMISED LOGISTICS

Palletising patterns can be set up and optimised according to specific logistics' and pallet strength's requirements.

ENERGY SAVING

To reduce waste and consumption, the machine can be equipped with a system for recovering kinetic energy.

MADE TO LAST

A robust frame, high-quality manufacturing and top brand components ensure a long life cycle, with minimal maintenance required over time.

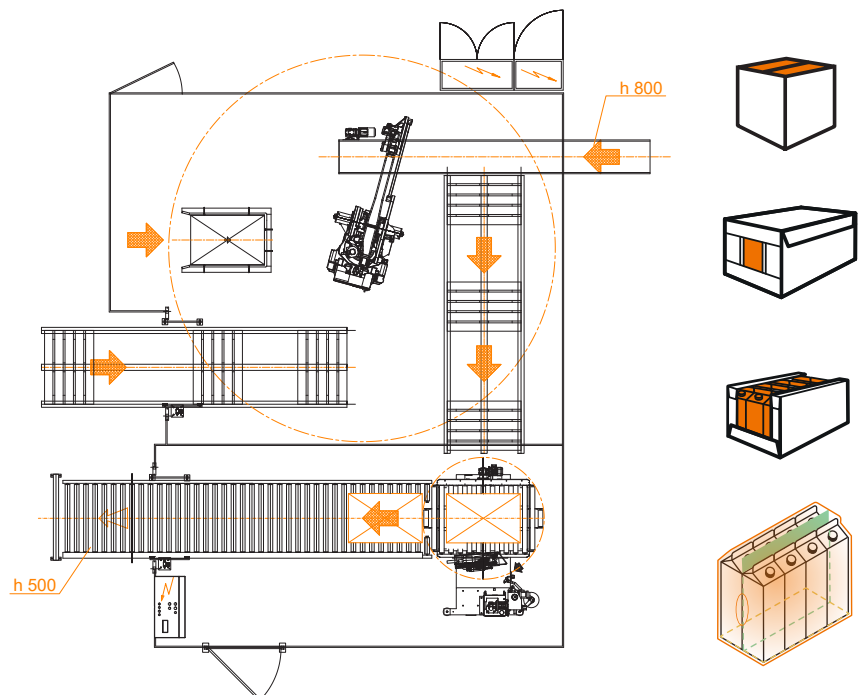

TECHNICAL FEATURES

DIMENSIONS (mm)	2500x2000x4500
PICK-UP WEIGHT (kg)	Up to 50
LINES	1-2
INSTALLED POWER AND AVERAGE CONSUMPTION	19kW-400V Average 7kW
WEIGHT (Kg)	1200
CAPACITY	240 cycle/h Up to 780 cycle/h
COMPRESSED AIR	200 nl/min. - 6 bar