

# Pick and Place

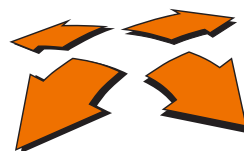

A **GALDI** COMPANY

**ARTEMA PACK**  
packaging & automation

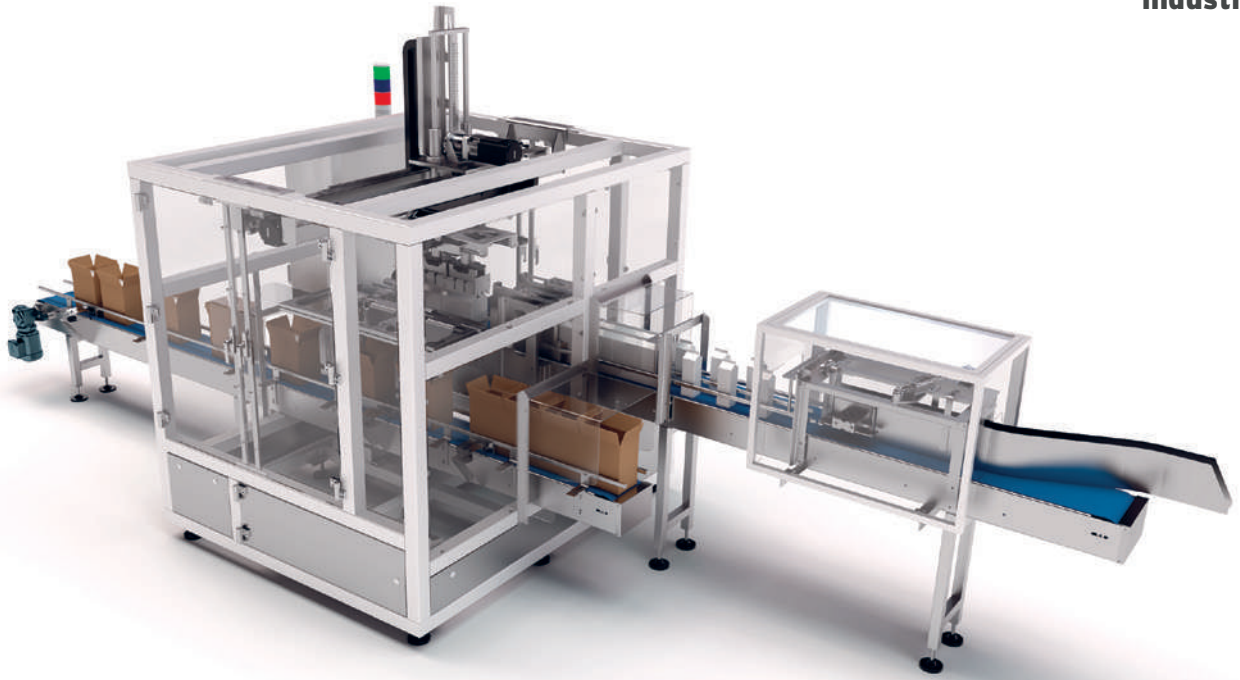

## MADE TO LAST

A robust frame, high-quality manufacturing and top brand components ensure a long life cycle, with minimal maintenance required over time.

## MULTI-PACKAGING

The ability to handle both American and tray boxes ensures greater production flexibility.

## COMPLETE PICKING

Both a box forming and a box closing system can be combined with the machine.

## ERGONOMICS

Designed to simplify the work of operators and maintenance technicians, the machine offers simplicity of use and easy accessibility.

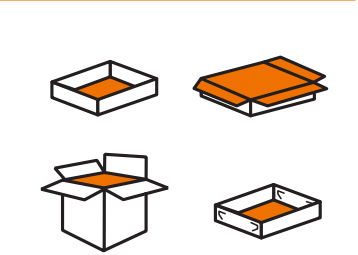
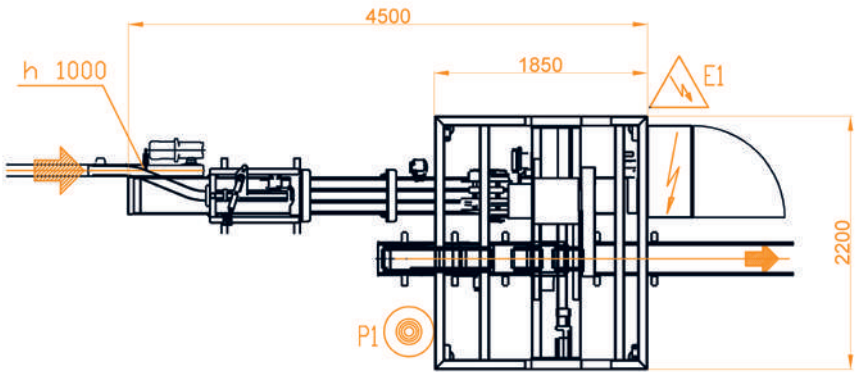
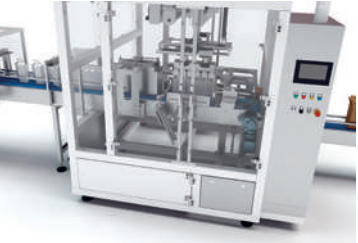

TECHNICAL FEATURES						
DIMENSIONS (mm)	INFEEED HEIGHT FROM GROUND LEVEL (mm)	OUTFEED HEIGHT FROM GROUND LEVEL (mm)	INSTALLED POWER AND AVERAGE CONSUMPTION	WEIGHT (Kg)	CAPACITY	COMPRESSED AIR
5000x2200x2737	1000	650	15kW-400V Average 7kW	1.500	20 box/min 1.200 box/h	400 nl/min. - 6 bar